

Standard key orientation

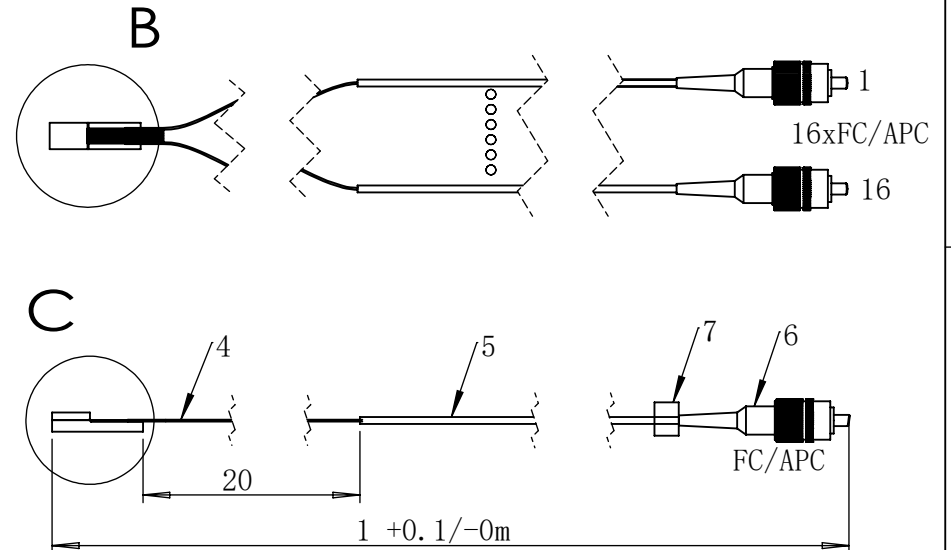
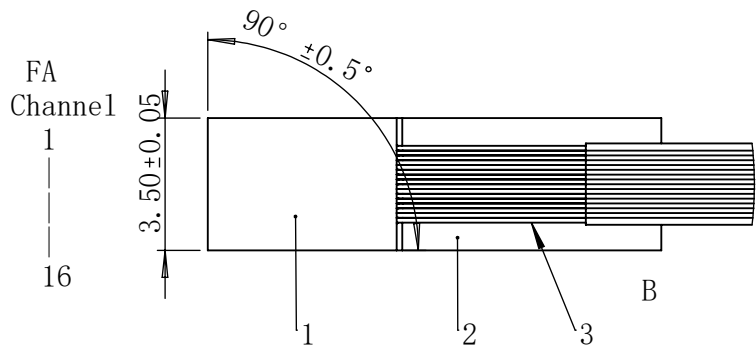
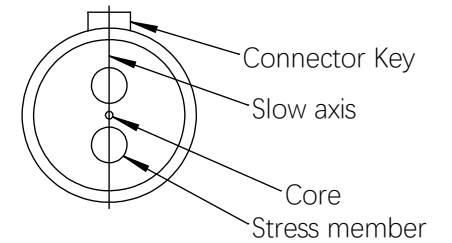

ITEM	PART	MATERIAL	DESCRIPTION	QTY
1	Array lid	Glass	3.5x5x1	1
2	Array base	Glass	16V-127P-3.5x12x5x1.5t	1
3	Cladding fiber	Glass	/	16
4	Bare fiber	Glass+Acrylate	Corning PM15-U25D fiber	16
5	Fiber jacket	Hytrel	0.9mm blue loose tube	16
6	Fiber Connector	Nickel plated brass	FC/APC	16
7	Wear cable marker	Polyethylene	Number : 1-16	16

REV.	DESCRIPTION	DATE	REVISED
A		2024/1/4	D2

DIMENSIONS ARE IN MM		NAME	DATE
X ± 0.15		D2	2024/1/4
.X ± 0.10		Q.A.	2024/1/4
.XX ± 0.05			
ANGULAR ± 0.5°			
ALL MACHINED SURFACE TO BE	3.2	PROPRIETARY AND CONFIDENTIAL	
BREAK SHARP CORNERS MAX		THE INFORMATION CONTAINED IN THIS DRAWING IS THE SOLE PROPERTY OF PHIX PHOTONICS ASSEMBLY. ANY REPRODUCTION IN PART OR AS A WHOLE WITHOUT THE WRITTEN PERMISSION OF PHIX PHOTONICS ASSEMBLY IS PROHIBITED.	

TITLE:		SIZE	PART NO. or DWG. NO.	REV
DK-16ch PMFA-FC_APC		A4	30150566 152604	A
SCALE:1:1				SHEET 1 OF 1